

## East African Journal of Information Technology

[eajit.eanso.org](http://eajit.eanso.org)

Volume 5, Issue 1, 2022

Print ISSN: 2707-5346 | Online ISSN: 2707-5354

Title DOI: <https://doi.org/10.37284/2707-5354>



EAST AFRICAN  
NATURE &  
SCIENCE  
ORGANIZATION

Original Article

### An IOT Based Landslide Detection and Early Warning System in Hilly Areas: A Case Study of Bududa District, Eastern Uganda.

Lusiba Badru<sup>1\*</sup>, Dr. Semwogerere Twaibu, PhD<sup>1</sup>, Oguti Victoria<sup>1</sup> & Dr. Gilbert Gilibrays Ocen, PhD<sup>1</sup>

<sup>1</sup> Busitema University, P. O. Box 236, Tororo, Uganda.

\* Correspondence ORCID: <https://orcid.org/0000-0002-7276-844>; email: [tsemwogerere@eng.busitema.ac.ug](mailto:tsemwogerere@eng.busitema.ac.ug).

Article DOI: <https://doi.org/10.37284/eajit.5.1.588>

**Date Published: ABSTRACT**

21 March 2022 Landslides are the gravitational movements of soil, rock down slopes that can cause several damages to the environment. It is one of the most common occurring natural phenomena worldwide in causing great loss of lives and property. The study aimed at developing a Web-Based Landslide Detection and Alert System to monitor and alert people in landslide-prone areas in time. Quantitative experimental designs were employed targeting parameters like soil pore pressure, soil vibration, soil movement, rain intensity and humidity. These are sensor-monitored and their values are analysed for the system development. These values are transmitted to the monitoring section via the internet and people get notified by a text “landslide detection alert” by using GSM. Findings are expected to contribute towards disaster preparedness and eventual loss of lives and property. It is therefore recommended for use in such prone areas by the ministry and other organs of concern.

**Keywords:**  
*Detection,*  
*Alert System,*  
*Disaster,*  
*GSM,*  
*IoT,*  
*Landslide.*

#### APA CITATION

Badru, L., Twaibu, S., Victoria, O., & Ocen, G. G. (2022). An IOT Based Landslide Detection and Early Warning System in Hilly Areas: A Case Study of Bududa District, Eastern Uganda. *East African Journal of Information Technology*, 5(1), 31-38. <https://doi.org/10.37284/eajit.5.1.588>

#### CHICAGO CITATION

Badru, Lusiba, Semwogerere Twaibu, Oguti Victoria, & Gilbert Gilibrays Ocen. 2022. “An IOT Based Landslide Detection and Early Warning System in Hilly Areas: A Case Study of Bududa District, Eastern Uganda”. *East African Journal of Information Technology* 5 (1), 31-38. <https://doi.org/10.37284/eajit.5.1.588>.

#### HARVARD CITATION

Badru, L., Twaibu, S., Victoria, O., & Ocen G. G. (2022) “An IOT Based Landslide Detection and Early Warning System in Hilly Areas: A Case Study of Bududa District, Eastern Uganda”, *East African Journal of Information Technology*, 5(1), pp. 31-38. doi: 10.37284/eajit.5.1.588.

#### IEEE CITATION

L. Badru., S. Twaibu., O. Victoria., & G. G. Ocen. "An IOT Based Landslide Detection and Early Warning System in Hilly Areas: A Case Study of Bududa District, Eastern Uganda", *EAJIT*, vol. 5, no. 1, pp. 31-38, Mar. 2022.

#### MLA CITATION

Badru, Lusiba, Semwogerere Twaibu, Oguti Victoria, & Gilbert Gilibrays Ocen. "An IOT Based Landslide Detection and Early Warning System in Hilly Areas: A Case Study of Bududa District, Eastern Uganda". *East African Journal of Education Studies*, Vol. 5, no. 1, Mar. 2022, pp. 31-38, doi:10.37284/eajit.5.1.588.

## INTRODUCTION

Landslide occurs when the balance between a hill's weight and the countering resistance forces is tipped in favour of gravity (Musinguzi & Asiimwe, 2014; Rastetter, 2004; Selby, 1993; Tanaka, 2013). This is because of the gravitational force which acts to move material downhill and is usually counteracted by two things: the internal strength of the material, and the friction of the material on the slope (Selby, 1993). Therefore, any change to the earth's surface that reduces friction increases the likelihood of landslide occurrence (Badru et al., 2019). Since landslide occurrence is unpredictable and occurs within a very short life span (Tien et al., 2016), there is a need for technology that allows those responsible for disaster reduction to keep monitoring the factors which trigger landslides.

Web-based landslide detection and the alert system helps to fulfil the need for real-time monitoring of landslide occurrences in landslide-prone areas. This, in turn, shall help to save people's lives and property in time.

### Study Objective

The main objective of this project was to develop a web-based landslide detection and alert system. For this purpose, several sensors were deployed in the landslide-prone area. The critical issue with this system was to ensure that sensor values are accessed on the web application, installed on the local machine, and its capability to send a text to people alerting them about landslide detection in real-time. This paper introduces a new method of landslide detection, which integrates wireless technology and GSM technology.

### Existing System

The existing system being used for landslide monitoring is achieved manually as the responsible people facilitate the experts to go in the landslide-

prone area, make a survey and draw conclusions about landslide occurrence, which makes it inaccurate, time-wasting, and unreliable (Dinagar, 2015; Ramesh & Kumar, 2009; Georgieva et al., 2012; Ahrens and Rudolf, 2006). Other available systems monitor very few parameters such as temperature, humidity, and soil vibration, which may not be sufficient (Krol & Bernard, 2012; Hinge & Bawage, 2014).

### Proposed System

In this study, landslide monitoring was achieved through sensor technologies and GSM technology for alerting people. There is no need for manual work and any other surveying instruments to monitor landslides. This method is automated to acquire soil properties. The triggering parameters like moisture, soil movement, pressure, vibration, and rainfall intensity of landslides are monitored here. These values from the field are transmitted to the web application using Wi-Fi technology. Early warning for the potential landslide hazard is provided to the people in a very fast and timely manner. Therefore, there is enough time to save human lives and their properties.

## METHODS AND MATERIALS

### Block Diagram of the System

The sensors like vibration sensor, pressure sensor, accelerometer, humidity sensor, and rain sensor are deployed in the landslide-prone area. These sensors detect signals and transform them into digital form for further processing by the microcontroller ATMEGA328P (<https://osoyoo.com/2018/>, 2018; <https://www.openhacks.com/>, 2020; <https://create.arduino.cc/projecthub>, 2020; <https://www.electronicwings.com/sensors>, 2020). The processed values are sent to the data analysis center via the internet.

These values are sent to the PC and compared with the pre-determined values that are programmed. If

soil vibration and soil movement are HIGH, people are alerted using the GSM.

**Figure 1: System Block**

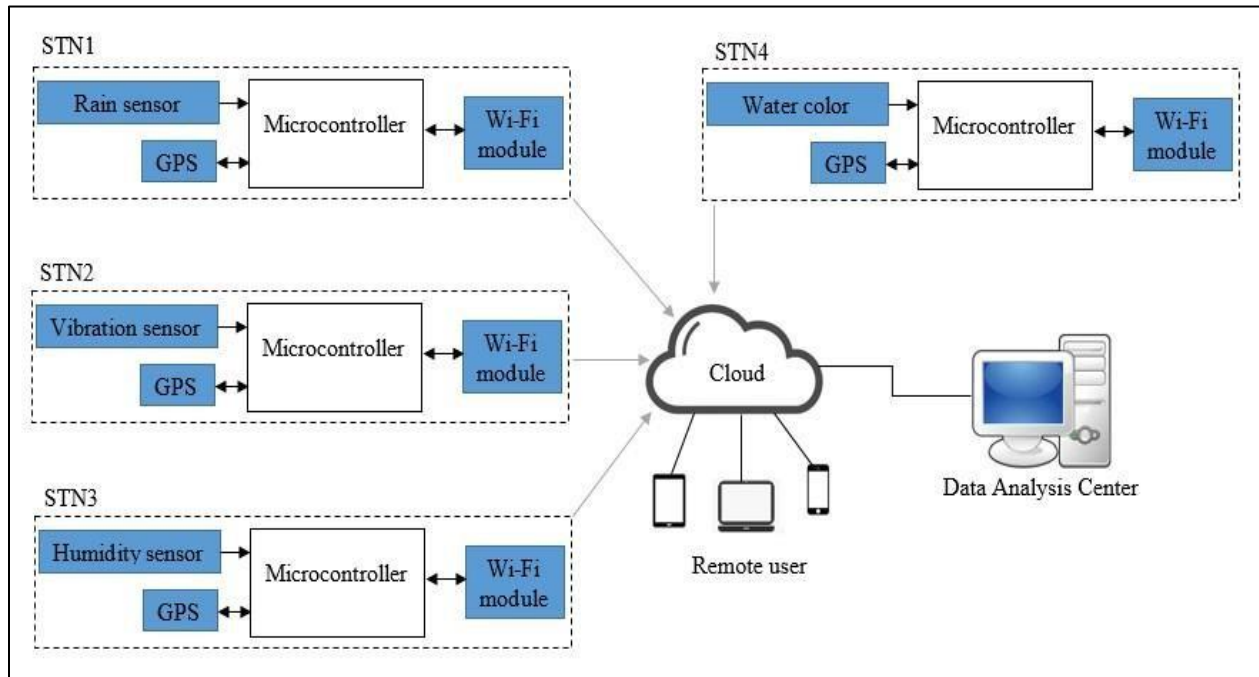

**Tools Used**

To design the hardware components of the system prototype, the following tools/resources were used.

*The Microcontroller (Atmega328PP chip for Arduino).* The microcontroller contains the processing unit that processes the received data from the sensors. It is programmed with fixed standard parameters and in case of any deviations from the required values, the relevant authorities and the general public will be notified.

*Electronic Components.* Different components will be used mainly to regulate and direct rightful amounts of current in the system. These included Diodes, capacitors, resistors and transistors.

*Rain sensor.* This is used for measuring the intensity of rain. It is a resistive type sensor if rain increases; the resistance of the rain sensor increases and that is

the ADC value of the rain sensor. A rain sensor is used to measure the intensity of rain. The effect of rainfall infiltration on a slope can result in changing soil suction and positive pore pressure

*Vibration Sensor.* It is used for detecting soil vibration. This sensor has two contact pins, an external force is acted upon either by movement or vibration, the sensors' two-contact pins are closed and contact is made between the two pins. When the force is removed the sensor terminals return back to open contacts. It is commonly used in electronics toys, alarms, domestic appliances, electronic devices, etc. SW-580PT is a suspended spring-type vibration sensor or switch. In the static condition, the switch is open and this is the default state. When the sensor experiences movement or vibration the switch closes shortly. This sensor does not measure the amplitude of the vibration, but can very easily detect the presence of vibration or movement of any kind in any direction.

**Figure 2: Vibration Sensor and Rain Sensor**



*Accelerometer.* The accelerometer sensor (The ADXL335) is a small, thin, low-power, complete 3-axis accelerometer with signal conditioned voltage outputs. The product measures acceleration with a minimum full-scale range of  $\pm 3$  g. It can measure the static acceleration of gravity in tilt-sensing applications, as well as dynamic acceleration

resulting from motion, shock, or vibration. This is illustrated in *Figure 3*.

*Humidity Sensor.* Soil moisture sensors or humidity sensor probes are continuously deep into the soil. If soil moisture increases the resistance of the sensor increases this is the ADC value of the controller.

**Figure 3: Humidity Sensor and Accelerometer Sensor**



*Pressure Sensor.* The pressure sensor detects pressure values between the pores of the soil and produces voltage output to the microcontroller.

information to the servers. It consists of the Wi-Fi module that collects the processed data from the microcontroller and delivers it to the data analysis centres through the internet.

*The transmission system.* The transmission system is responsible for transferring the collected

**Figure 4: Wi-Fi module ESP8266 Pressure Sensor (<https://www.electroschematics.com/neo-6m-gps-module/>) and Transmission System**

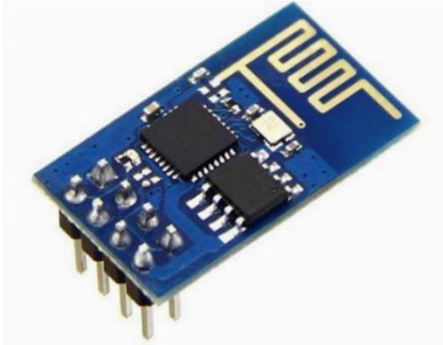

*The GPS.* The GPS module helps tell the location of the stations. It is attached on each system and helps in identifying the location of the station where the problem is originating from (<https://www.electroschematics.com/neo-6m-gps-module/>..., 2020). This is illustrated in *Figure 5*.

**Figure 5: GPS Module**



The project was limited to the development of a web-based landslide detection and alert system for monitoring the factors, which always trigger landslides in Bududa district and other similar areas. It alerts people of Bududa before landslides occur. It uses a humidity sensor for sensing soil moisture content, a pressure sensor for measuring the soil pore pressure, an accelerometer sensor for detecting soil movement resulting from motion or shock, a vibration sensor for detecting the soil vibration, and a rain sensor for measuring the rain intensity. The sensors send data is sent to the microcontroller for processing. When there is any kind of landslide indicator, target people are alerted via the GSM.

**Flow Chart of the System**

Flowcharts are an important technique for modelling a system’s high-level detail by showing how input data is transformed to output results through a sequence of functional transformations

**Figure 6: System Flow Chart**

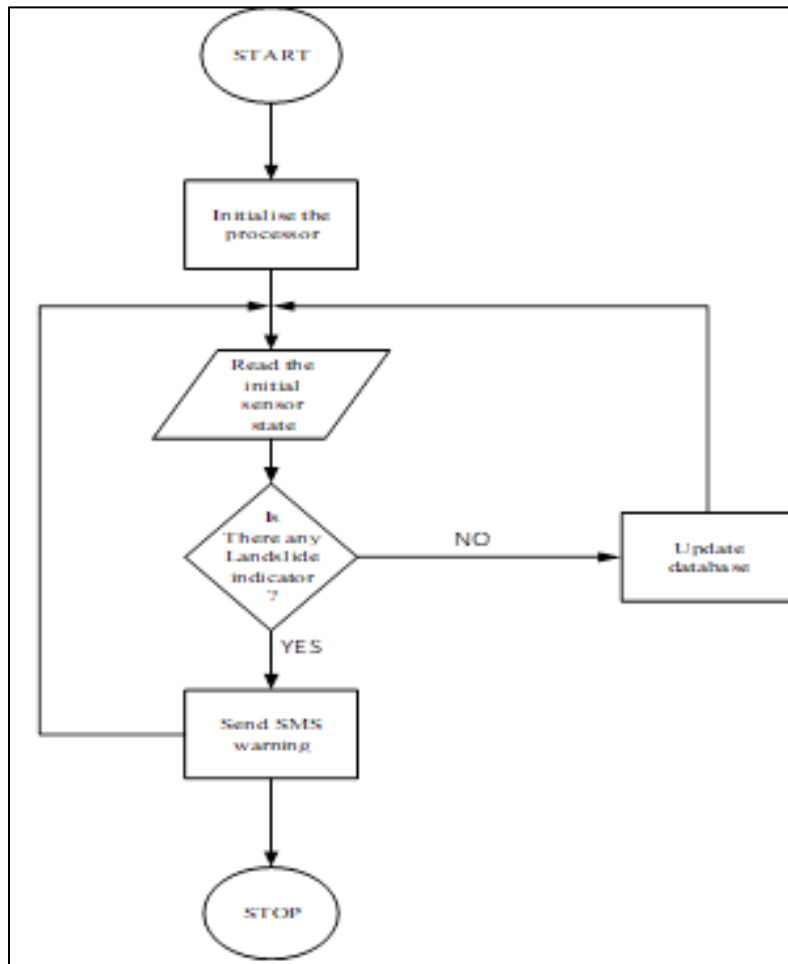

**RESULTS AND DISCUSSIONS**

**System Design**

A system design for landslide monitoring is done through sensor technologies and GSM technology (Dinagar, 2015) for alerting based on IOT. The triggering parameters like moisture, soil movement, pressure, vibration, rainfall intensity, river water levels and quality with respect to landslides are monitored here. These values from the field are transmitted to the internet using Wi-Fi technology. Early warning for the potential landslide hazard is provided to the people in a very fast manner. Therefore, there is enough time to save human lives and their properties.

**System Operation**

Landslide monitoring was achieved through sensor technologies and GSM technology for alerting people. There is no need for manual work and any other surveying instruments to monitor landslides. This method is automated to acquire soil and properties. The triggering parameters like moisture, soil movement, pressure, vibration, rainfall intensity, river water levels and quality with respect to landslides are monitored here. These values from the field are transmitted to the internet using Wi-Fi technology.

The sensors like vibration sensor, pressure sensor, accelerometer, humidity sensor, water level sensor, and rain sensor are deployed in the landslide-prone areas independently. These sensors detect signals and transform them into digital form for further processing by the microcontroller ATMEGA328P.

The processed values are sent to the data analysis center via the internet. The station results from each station are processed by a station microprocessor and communicated as observed in *Figure 7*. Early

warning for the potential landslide hazard is provided to the people in a very fast manner. Therefore, there is enough time to save human lives and their properties.

**Figure 7: Screen Display of the System Information**



## CONCLUSION AND RECOMMENDATIONS

The objective of the project was achieved, to develop an early warning system based IoT to detect and alert for landslides. We believe it is better than the current system being used. The ministry only facilitates the rescue team after seeing that landslide has been detected.

The system is recommended for use by the Ministry of Relief and Disaster Preparedness of Uganda, to monitor landslides in Bududa. However further tests should be carried out with the system in order to deal with the different vulnerabilities that may come up. The project work gives a lot of confidence to fight out in this challenging world.

## REFERENCES

Dinagar, A., Karthick, P., Karthi, K., Tamilvanan, P., & Premkumar, S. (2015). Landslide Monitoring System with GSM Module. *International Journal of Innovative Research in Computer and Communication Engineering*, 3(Special Issue 2).

Ramesh, M. V. (2009, June). Real-time wireless sensor network for landslide detection. In *2009 Third International Conference on Sensor*

*Technologies and Applications* (pp. 405-409). IEEE.

Tien Bui, D., Pham, B. T., Nguyen, Q. P., & Hoang, N. D. (2016). Spatial prediction of rainfall-induced shallow landslides using hybrid integration approach of Least-Squares Support Vector Machines and differential evolution optimization: a case study in Central Vietnam. *International Journal of Digital Earth*, 9(11), 1077-1097.

Georgieva, K., Smarsly, K., König, M., & Law, K. H. (2012). An autonomous landslide monitoring system based on wireless sensor networks. In *Computing in Civil Engineering (2012)* (pp. 145-152).

Ahrens, J., & Rudolph, P. M. (2006). The importance of governance in risk reduction and disaster management. *Journal of contingencies and crisis management*, 14(4), 207-220.

Musinguzi, M., & Asiimwe, I. (2014). Application of geospatial tools for landslide hazard assessment for Uganda. *South African Journal of Geomatics*, 3(3), 302-314.

Krol, O., & Bernard, T. (2012). ELDEWAS-Online early warning system for landslide detection by

means of dynamic weather nowcasts and knowledge-based assessment.

Tanaka, T. (2013). Landslide monitoring system. *International Journal of Landslide and Environment*, 1(1), 101-102.

Hinge, P. N., Hinge, P. N., & Bawage, R. R. (2014). Wireless Sensor Network for Detecting Vibrations Before Landslides. *IJERT*, 2278-0181.

Selby, M. J. (1993). *Hillslope Materials and Processes* Oxford Univ. Press.

Badru, L., Victoria, O., Patrick. A. Z., Felix. B. (2019). Water Parameters/Characteristics of the Rivers/Channels in the Landslide Prone Areas of Bududa Uganda.

Rastetter, E. B., Kwiatkowski, B. L., Le Dizès, S., & Hobbie, J. E. (2004). The role of down-slope water and nutrient fluxes in the response of Arctic hill slopes to climate change. *Biogeochemistry*, 69(1), 37-62.

“Rain Sensor Module”. Accessed on: Jan. 31st, 2020. [Online]. Available: [https://www.openhacks.com/uploadsproductos/rain\\_sensor\\_module.pdf](https://www.openhacks.com/uploadsproductos/rain_sensor_module.pdf).

14 “Vibration Sensor Module,” Nov. 14, 2018. Accessed on: Jan. 31st, 2020. [Online]. Available: <https://osoyoo.com/2018/11/14/arduino-lesson-vibration-sensor-module>

“Soil Moisture Sensor”. Accessed on: Jan. 31st, 2020. [Online]. Available: <https://create.arduino.cc/projecthub/MisterBotBreak/how-to-use-a-soil-moisture-sensor-ce769b>.

“ESP8266-01”. Accessed on: Jan. 31st, 2020. [Online]. Available: <https://www.electronicwings.com/sensors-modules/esp8266-wifi-module>

“GPS- module”. Accessed on: Jan. 31st, 2020. [Online]. Available: <https://www.electroschematics.com/neo-6m-gps-module/>.